

Fig. 100CT, 100CLS Compression Ended DZR - T-Handle or Lockshield



FEATURES AND BENEFITS

- Dezincification resistant
- Light, compact and easy to install and operate
- Improved leak protection
- More resistant to damage during installation
- Sizes from 15 to 54mm
- WRAS Approved



Fig. 100CT

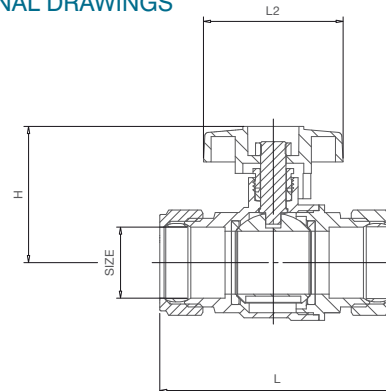

Fig. 100CLS

MATERIAL SPECIFICATION

Component	Material
Hex-Nut	Steel Plated
T-Handle	Aluminium AL-46100 Green
Packing Nut	Brass CW617N
Packing Gland	PTFE WRAS Approved
Body	DZR Brass CW602N
Seats	PTFE WRAS Approved
Ball	DZR Brass CW602N Chrome Plated
Bonnet	DZR Brass CW602N
Compression Olive	Brass CW507L
Compression Nut	DZR Brass CW602N
Stem	DZR Brass CW602N
Lockshield	Brass CW617N
Lockshield Cover	Polypropylene Green

DIMENSIONAL DRAWINGS



PRESSURE/TEMPERATURE RATINGS COMPRESSION

Temperature °C	-10 - 30	40	50	65	80	90	100	110	120
Pressure bar	16	14.3	12.6	10	8.7	7.8	6.9	6	5

Intermediate pressure ratings shall be determined by interpolation

DIMENSIONS AND WEIGHTS

Nom Size	Fig	mm	15	22	28	35	42	54
L		mm	66.5	80	92.5	104.5	122	141
L2		mm	50	50	55	82	82	110
H	CT	mm	40	43	54	61	67	80.5
H	CLS	mm	42	45	59.5	67	73.5	86.5
Weight	CT	kg	187	343	567	977	1487	2634
Weight	CLS	kg	220	376	614	1039	1549	2437

SPECIFICATION

UK End Connection: Compression ends to BS EN 1254-2:1998.
Operator: T-Handle/Spanner/Socket. Quarter turn.
PTFE seats and stem seal.
WRAS listed.

Every effort has been made to ensure that the information contained in this publication is accurate at the time of publishing. Hattersley Ltd assumes no responsibility or liability for typographical errors or omissions or for any misinterpretation of the information within the publication and reserves the right to change without notice.