

Fig. 951 and 951G Semi-lugged, Lever/Gearbox Operated Wafer Pattern to BS EN 593: 2009

FEATURES AND BENEFITS

- Aluminium Bronze disk
- Stainless Steel shaft
- 951 - Trigger lever, 951G - Gearbox operated
- Sizes 350 to 600mm PN16 only
- Valves are suitable for use with flanges conforming to BS EN 1092-2: 1997 PN10 or PN16 and ANSI B16.1 Class 125 (sizes 2" to 12")



MATERIAL SPECIFICATION

Component	Material
Body	Ductile Iron ASTM A536 (Epoxy Paint)
Disk	Aluminium Bronze
Liner	Nitrile Temp. -10 to 90°C
Shaft	Stainless Steel Type 410
Taper Pin	Stainless Steel Type 316
Key	Carbon Steel
O-Ring	Buna-N
Bushing	PTFE
Lever & Screw	Carbon Steel (Epoxy Paint)
Stop Plate	Carbon Steel (Zn Plated)

PRESSURE/ TEMPERATURE RATING

PN16 from -10 up to 90°C

TEST PRESSURES

Each valve is individually hydrostatically tested to BS EN 12266-1: 2003 at the following test pressures:

Shell: 24 bar
Seat: 17.6 bar

SPECIFICATION

Semi-lugged
Lever or gearbox
Valves DN250 and larger supplied as standard with a fully enclosed gear operator
Valves may be used for flow regulation
Suitable for gas applications
Fig. 951 and 951G are suitable for Group 1 and 2 gases and Group 1 and 2 liquids as defined by the Pressure Equipment Directive 97/23/EC

DIMENSIONS AND WEIGHTS

Fig 951

Nom Size	mm	50	65	80	100	125	150	200
A	mm	195	207	213	232	245	257	305
B	mm	83	95	102	124	136	150	197
C	mm	44	48	48	54	57	57	63
D	mm	32	32	32	32	32	32	44
E	mm	102	121	130	171	197	219	268
F	mm	260	260	260	260	260	260	356
G	mm	32	46	64	90	111	145	193
Weight	kg	3.5	4	5.4	6.7	9	9.9	16.4

Fig 951G

Nom Size	mm	50	65	80	100	125	150	200	250	300	350	400	450	500	600
A	mm	162	175	181	200	213	225	260	292	337	368	400	422	479	562
B	mm	83	95	102	124	136	150	197	210	248	279	305	381	381	457
C	mm	44	48	48	54	57	57	63	70	79	79	89	108	133	156
D	mm	42	42	42	42	42	42	40	40	40	40	-	-	-	-
E	mm	102	121	130	171	197	219	268	332	410	435	508	543	592	708
F	mm	150	150	150	150	300	300	300	300	300	300	450	450	450	450
G	mm	32	46	64	90	111	145	193	241	290	325	380	427	474	574
K	mm	240	240	240	240	240	240	230	230	230	230	277	277	321	335
Weight	kg	15	15.5	16.9	18.2	20.5	21.4	29	33.5	45.8	56.2	88.4	110.2	160.5	260

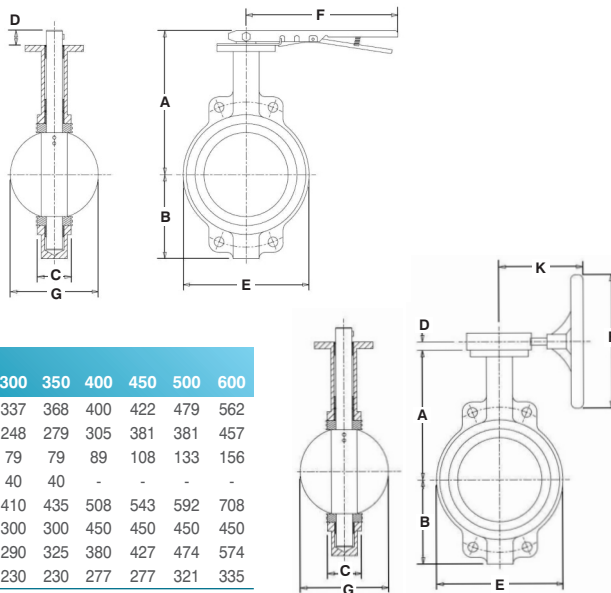

Every effort has been made to ensure that the information contained in this publication is accurate at the time of publishing. Crane Ltd assumes no responsibility or liability for typographical errors or omissions or for any misinterpretation of the information within the publication and reserves the right to change without notice.